

Key Features

- Removes oil mist from vacuum pump exhaust
- Protects clean rooms from pump vapors
- Keeps oil residue from sticking to furniture, walls, and floors
- Coalescing filters require little maintenance

When you start a vacuum pump, a cloud of gray “smoke” comes out of the exhaust. That’s a mist of pump fluid. After the pump has been running for a while, you may not see the mist, but it’s still there. A haze forms in rooms where vacuum pumps are running—oil mist gets into the air, settles on surfaces, and you breathe it. Oil mist is a nuisance everywhere—but it’s especially bad in clean rooms. If you’ve ever touched a sticky tabletop near a vacuum pump, you know that cleaning up after oil mist is no joke.

There’s an easy answer to the oil mist problem—install an MV VisiMist Oil Mist Eliminator on your pump’s exhaust line. Pump exhaust passes through pleated, low-resistance microfiberglass coalescing filters that remove mist before it gets into room air. Unlike conventional filters, which are quickly saturated with absorbed oil, a coalescing filter forms oil drops which flow to the bottom of the filter housing. The result? Coalescing fibers effectively remove oil longer than conventional designs, so you’re not changing filters all the time.



CALL TO ORDER

(978) 667-2393

MV Products
247 Rangeway Road, P.O. Box 359
North Billerica, Massachusetts 01862-0359

Fax: (978) 671-0014
E-mail: sales@massvac.com
Web: www.massvac.com

SPECIFICATIONS

Construction	Polypropylene housing; styrene acrylonitrile sump.
Connectors	Up to 1" (25 mm). VisiMist requires a hose connector or 25 mm NW flange termination and an adapter for the make and model vacuum pump.
Mountings	Above pump or to the side.
Filter	Pleated microfiberglass.
Dimensions	Diameter: 5.5" (140 mm) Height: 9.1" (231 mm) Weight: 2.5 lbs. (1.1 kg)



ORDERING INFORMATION

Description	Part Number
VisiMist Oil Mist Elimator with filter element	360500
VisiMist Fittings	
NW 25 Flange—for VisiMist Intake.	301025
Hose termination 3/4"—an alternative for the NW 25 flange.	301075
NW 25 Stand-Off Adapter—for mounting VisiMist above the pump. Connects to VisiMist on short arm, terminates in NW 25 flange on long arm.	301100
Pump Mountings	
Pump Exhaust Adapter—to NW 25 (Specify pump manufacturer and model number.) Not required if pump exhaust terminates in an NW 25 flange.	301110*
NW 25 Elbow—for vertical orientation of VisiMist. Connects to NW 25 flanges.	301425
NW 25 Blank Flange—for custom-made adapters.	301125
Connectors	
NW 25 Clamp—for joining two NW 25 flanges. Requires NW 25 Centering Ring (below).	301225
NW 25 Centering Ring—includes one "O" ring.	301325
NW 25 "O" ring—spare "O" ring for replacements.	301525
Filters	
Microfiberglass Coalescing Filter Element (15% discount in lots of 10 or more)	360905

* Number may vary. Check with factory for correct part number and price for specific pump models.

Also visit us on the web at:
www.massvac.com

CALL TO ORDER
(978) 667-2393

Installation Drawings

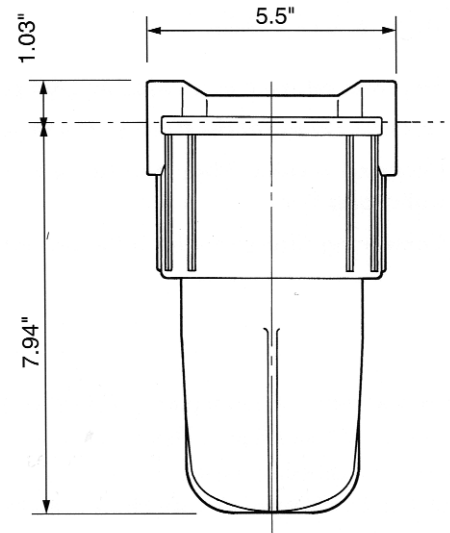

VisiMist

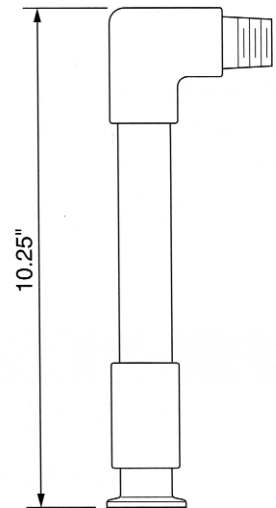

Stand-Off Adapter